

Intelligent Driver

Two-Axis Stage Controller

GSC-02



User's Manual



 **OptoSigma®**

Notes regarding these materials

- These materials are intended as a reference to assist our customers in the use of the SIGMAKOKI CO., LTD. Product best suited to the customer's application; they do not convey any license under any intellectual property rights, or any other rights, belonging to SIGMAKOKI CO., LTD. or a third party.
- SIGMAKOKI CO., LTD. assumes no responsibility for any damage, or infringement of any third-party's rights, originating in the use of any product data, diagram, charts, programs, or algorithms contained in these materials.
- All information contained in these materials, including product data, diagrams, charts, programs and algorithms represents information on products at the time of publication of these materials, and are subject to change by SIGMAKOKI CO.,LTD. without notice due to product improvements or other reasons.
- When using any or all of the information contained in these materials, including product data, diagrams, charts, programs, and algorithm, please be sure to evaluate all information and products. SIGMAKOKI CO., LTD. assumes no responsibility for any damage, liability or other loss resulting from the information contained herein.
- SIGMAKOKI CO., LTD. products are not designed or manufactured for use in equipment or system that is used under circumstances in which human life is potentially at stake. SIGMAKOKI CO., LTD. products cannot be used for any specific purposes, such as apparatus or systems for transportation, vehicular, medical, aerospace, nuclear, or undersea repeater use.
- The prior written approval of SIGMAKOKI CO., LTD. is necessary to reprint or reproduce in whole or in part these materials.
- If these products or technologies are subject to the Japanese export control restrictions, they must be exported under a license Japanese government and cannot be imported into a country other than the approved destination.
Any diversion or re-export contrary to the export control laws and regulations of Japan and/ or the country of destination is prohibited.



Contents

For Your Safety	2
Chapter 1: Before You Begin	3
1. Package Contents	3
2. Overview	4
3. The GSC-02 System	4
4. Parts of the GSC-02	5
Chapter 2: Basic Operations	6
5. GSC-02 Connection procedure	6
6. GSC-02 Setting	6
Chapter 3: Using GSC-02 to position Motorized Stages	9
7. Using Computer to position Motorized Stages	9
Chapter 4 : Specification	14
8. Specification	14
9. Connector Pin Numbers and Signals	15
10. Exterior Dimensions	16



For Your Safety

Before using this product, read this manual and all warnings or cautions in the documentation provided. Only Factory Authorized Personnel should be changes and/or adjust the parts of controller.

The Symbols Used in This Manual

 WARNING	 CAUTION
This symbol marks warnings that should be read and used to prevent serious injury or death.	This symbol indicates where caution should be used to avoid possible injury to yourself or others, or damage to property.

The above indications are used together with the following symbols to indicate the exact nature of the warning or caution.

Examples of Symbols Accompanying Warnings and Cautions	
	△ Symbols enclosed in a triangle indicate warnings and cautions. The exact nature of the warning or caution is indicated by the symbol inside (the symbol at left indicates risk of electrocution).
	○ Symbols enclosed in a circle mark indicate prohibitions (actions that must not be performed). The exact nature of the prohibition is indicated by the symbol inside or next to the circle mark (the symbol at left indicates that the product must not be disassembled).
	● Symbols inside a black circle mark actions that must be performed to ensure safety. The exact nature of the action that must be performed is indicated by the symbol inside (the symbol at left is used in cases in which the AC adapter must be unplugged to ensure safety).

Symbols on the product

The symbol mark on the product calls your attention. Please refer to the manual, in the case that you operate the part of the symbol mark on the product.

	This symbol labeled on the portion calls your attention.
--	--

Disclaimer of Liability

- ① SIGMAKOKI CO., LTD. does not accept liability for damages resulting from the use of this product or the inability to use this product.
- ② SIGMAKOKI CO., LTD. does not accept liability for damages resulting from the use of this product that deviates from that described in the manual.
- ③ SIGMAKOKI CO., LTD. does not accept liability for damages resulting from the use of this product in extraordinary conditions, including fire, earthquakes, and other acts of God, action by any third party, other accidents, and deliberate or accidental misuse.
- ④ If the equipment is used in a manner not specified by the SIGMAKOKI CO., LTD., the protection provided by the equipment may be impaired.

WARNING

- Do not use this product in the presence of flammable gas, explosives, or corrosive substances, in areas exposed to high levels of moisture or humidity, in poorly ventilated areas, or near flammable materials.
- Do not connect or check the product while the power is on.
- Installation and connection should be performed only by a qualified technician.
- Do not bend, pull, damage, or modify the power or connecting cables.
- Do not touch the products internal parts.
- Connect the earth terminal to ground.
- Should the product overheat, or should you notice an unusual smell, heat, or unusual noises coming from the product, turn off the power immediately.
- Do not turn on the power in the event that it has received a strong physical shock as the result of a fall or other accident.
- Do not touch the stage while operation.
- Use dry clothes only for cleaning the equipment.

Chapter 1: Before You Begin

1. Package Contents

Purchasers of the Stage Controller should find that the package contains the items listed below. Check the package contents using the following checklist. Contact your retailer as soon as possible in the event that you should find that any item is missing or damaged.

- GSC-02 Stage Controller: 1



- SCT-602 Terminal Cap: 1



- User's Manual (This Manual): 1



You can download sample software from our web page.

Web http://www.global-optosigma.com/en-jp/software/sample_en.html

2. Overview

This controller is two axes stage controller featuring stepping motor drivers.

When the GSC-02 is connected to an ordinary personal computer via an RS232C interface, the stage can be accurately moved to the desired position by simple commands sent from the PC.

3. The GSC-02 System

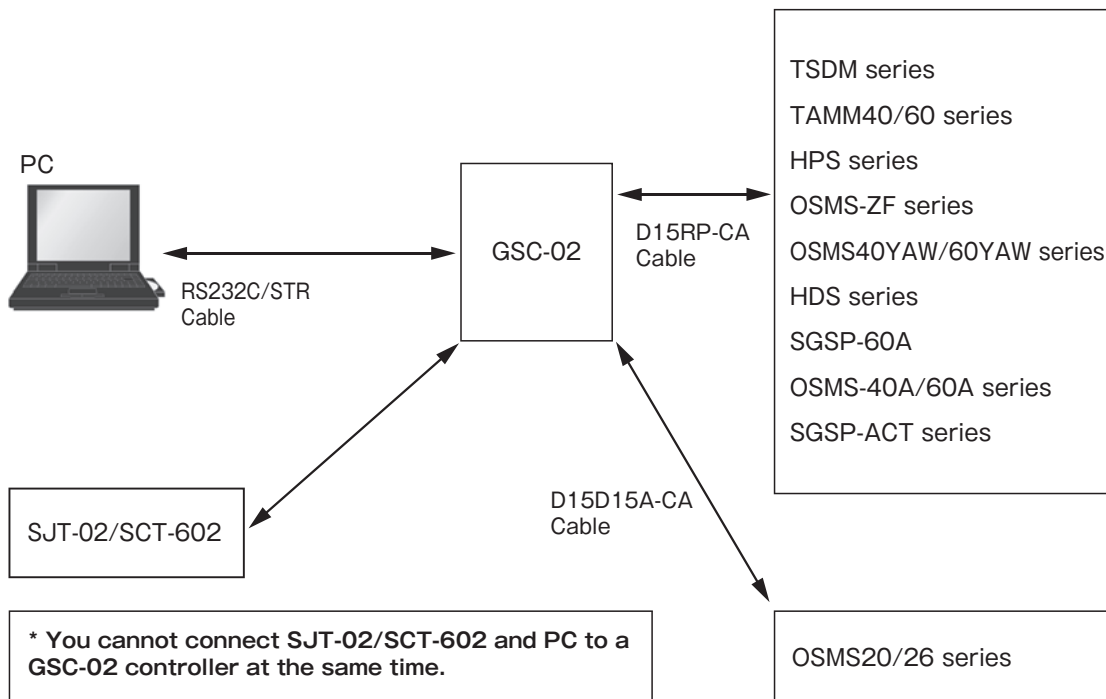

Note that applicable cables and drive current values are depending on the specifications of stages used. Check if your controller can adequately control desired devices before forming a system.



You cannot connect SJT-02/SCT-602 and PC to a GSC-02 controller at the same time. If you connect them in parallel, GSC-02, SJT-02/SCT-602, and/or PC may be damaged.

4. Parts of the GSC-02

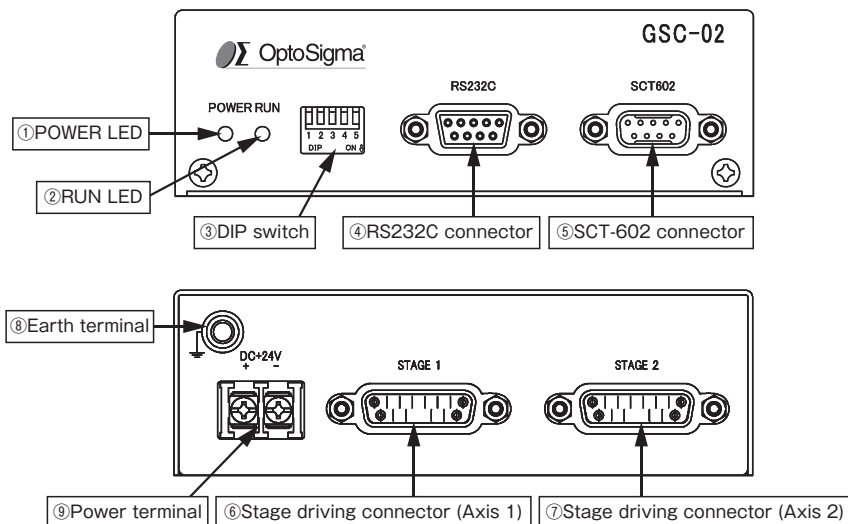

Functions:

- ① POWER LED : Lights up in green when powered.
- ② RUN LED : Lights up in red while driving stages.
- ③ DIP switch : Makes basic settings for GSC-02.
- ④ RS232C connector : This connector is used when the device is controlled from the computer via an RS232C interface.
- ⑤ SCT-602 connector : This connector is used when controlling with the SJT-02/SCT-602.
- ⑥, ⑦ Stage driving connector : Connect to the motorized stage of your choice. Supports up to two axes
- ⑧ Earth terminal : Should be grounded properly in your environment.
- ⑨ Power terminal : Connect to the power source (+24V, 2A).

Turn off a power supply in the case of the connector connection for security.

Make sure to set up and wire the cable supplying DC+24V and GND to the GSC-02 so that the maximum length of cable is not longer than 2m.

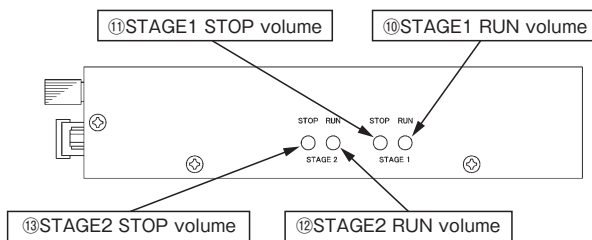

- ⑩ STAGE1 RUN volume : Volume control adjusting the RUN current output through the stage drive connector. (Axis 1)
- ⑪ STAGE1 STOP volume : Volume control adjusting the STOP current output through the stage drive connector. (Axis 1)
- ⑫ STAGE2 RUN volume : Volume control adjusting the RUN current output through the stage drive connector. (Axis 2)
- ⑬ STAGE2 STOP volume : Volume control adjusting the STOP current output through the stage drive connector. (Axis 2)

Chapter 2: Basic Operations

5. GSC-02 Connection procedure

5-1. Connecting to Motorized Stages

First, connect GSC-02 to the motorized stages.

- ① Please confirm the power source is turning off.
- ② Connect a standard cable (D15RP-CA/D15D15A-CA) to the connector of the motorized stage.
- ③ Connect the stage to be controlled as the first axis to the STAGE1 connector of the GSC-02 controller. Also connect the stage controlled as the second axis to the STAGE2 connector.

5-2. Connecting to PC and peripheral device

Connect GSC-02 to PC and peripherals (SJT-02/SCT-602).

RS232C interface is used for the connection between the PC and GSC-02.

The following descriptions premise the RS232C interface.

- ① Please confirm the power source is turning off.
- ② Use a genuine cable RS232C/STR, or 9-pin, D-SUB straight cable with male/female ends using inch screw threads.
- ③ Insert the male connector of communications cable in to the RS232C connector on the GSC-02. Insert the female end into the serial port on your PC.

6. GSC-02 Setting

Initialize your GSC-02 to match to the target stages and host environment (your PC, etc). The initialization includes DIP Switch settings and current adjustments (RUN/STOP) for each axis motor.

6-1. Set parameters with DIP Switch

Initialize your GSC-02 by setting each switch to ON/OFF as follows:

Parameter Assignment in the DIP Switch:

DIP Switch No.	Items	Parameters
1,2	Baud rate	2400/4800/9600/19200
3	Detecting the mechanical origin	MARK method/MINI method
4	Input logic for the limit sensor	Normal open/ Normal close
5	Specify whether to return mechanical origin for each axis	First axis only/ Both axis

Switch settings and Corresponding Parameters (Set to ON by turning to the down side)

Items	Dip Switch No.		Descriptions
	SW No.2	SW No.1	
Baud rate	ON	ON	2400bps
	ON	OFF	4800bps
	OFF	ON	9600bps
	OFF	OFF	19200bps
Detecting the mechanical origin	SW No.3		
	ON	OFF	MARK method
Input logic for the limit sensor	SW No.4		
	ON	OFF	Normal open
Specify whether to return mechanical origin for each axis	SW No.5		
	ON	OFF	First axis only
			Both axis

(Note) Shaded areas in the list show our factory settings. Tale care to handle the very small DIP Switch so as to avoid giving damage to them during the settings. Use appropriate tools such as sharp tweezers for setting switches on the DIP Switch. For our SGSP series stages, select Normal close for the limit sensor logic and MINI for the homing method.

Detecting the Mechanical Origin:

MINI method

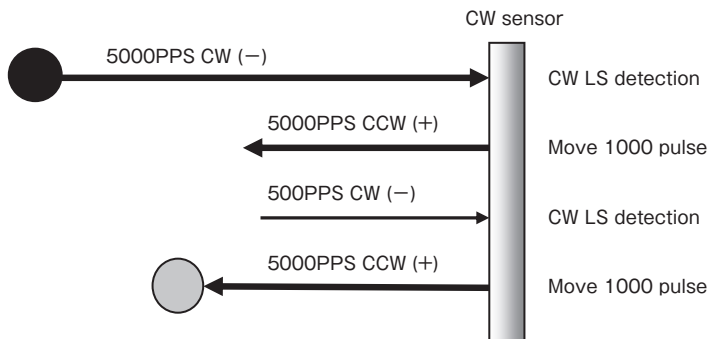

MARK method

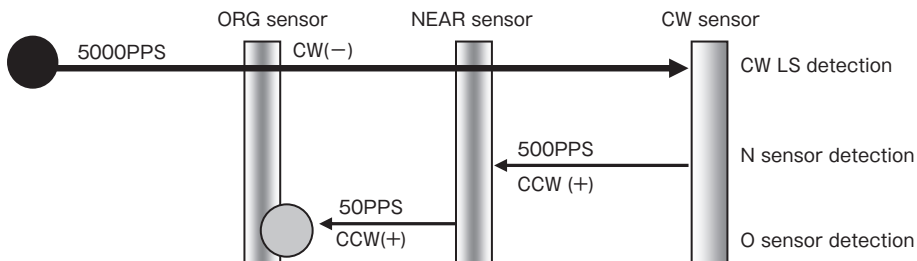

6-2.Setting the drive current

Set current values supplied from GSC-02 to stages. Turn a RUN current volume, provided on the side of the unit, to adjust RUN current corresponding to the stages to use. Use a STOP current volume to set a ratio to RUN current according to your conditions for the case where the current down function works. You can make each current adjustment for Axis 1 or Axis 2 independently.

Note that for the STOP current, adjustment is available not for current values, but for a ratio(%) to the RUN current.

Note) Generally the ratio of the STOP current to the RUN current is approx. 50%.

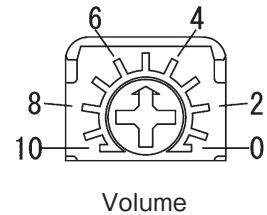

Driving current settings (RUN)

Factory-set to 0.35A/Phase

Volume No.	0	1	2	3	4	5	6	7	8	9	10
RUN current (A/phase)	0.3	0.31	0.32	0.33	0.4	0.5	0.6	0.68	0.75	0.79	0.8

Stop current settings (STOP current setting to 50% for RUN current)

Factory-set to volume No.0

RUN No.	0	1	2	3	4	5	6	7	8	9	10
STOP No.	0	0	0	0	1	1	2	2	3	3	3

Note) Each value cited in the above table is a guide to adjust the current without instrument, and may fluctuate within an allowable range.

6-3.Power ON

When you have completed procedures above, connect the power source. GSC-02 is power ON and the green power LED lights up.

Now the setup has been done, and your GSC-02 is ready to use. For the details of commands applicable to GSC-02, see Chapter 3.

Chapter 3: Using GSC-02 to position Motorized Stages

7. Using Computer to position Motorized Stages

The controller can be connected to a computer using an RS232C interface. Motorized stages can then be precisely controlled by commands (strings) transmitted from the computer.

The RS232C interface communication parameter of the GSC-02 is described below. Please set the configurations of the PC side according to the following table.

Items	Descriptions
Baud rate	Baud rate set with DIP Switch
Delimit	CR+LF
Parity	Non
Data bit	8bit
Stop bit	1bit
Flow control	Hardware (RTS/CTS)

7-1. List of Commands

The following is a list of available commands:

Command	String	Details
Return to mechanical origin	H :	Detect mechanical origin
Set number of pulses for relative movement	M :	Axis of movement, direction, number of pulses
Jog command	J :	Move at minimum speed (S)
Drive command	G	Start
Stop command	L :	Stop
Set electronic (logical) origin	R :	Set the electronic (logical) origin to the current position
Speed settings	D :	Set S, F and R
Free motor	C :	Excitation ON/OFF
Status1	Q :	Return current position etc.
Status2	! :	Return B(busy)/R(ready)
Internal information	? :	Check internal information

7-2. Command Format

Except for some status check commands (Q:, !:, ?:), no response will be returned to a command input. To determine whether or not a command was received normally, use the Q command to check status.

All commands are in single-byte characters.

7-3. Command in Detail

(1) H command: Return to mechanical origin

Features: This command is used to detect the mechanical origin for a stage and set that position as the origin. Once the mechanical origin has been detected, the value displayed will be 0. Each axis moves at the following constant conditions: Minimum speed (S): 500PPS, Maximum speed (F): 5000PPS, Acceleration/ Deceleration time (R): 200mS. Axes to home are depending on the DIP Switch settings.

Format:

- H: 1+ Detects mechanical origin for Axis 1 in the positive direction.
- H: 1- Detects mechanical origin for Axis 1 in the negative direction.
- H: 2+ Detects mechanical origin for Axis 2 in the positive direction.
- H: 2- Detects mechanical origin for Axis 2 in the negative direction.
- H: W++ Detects mechanical origin for Axis 1 in the positive direction, and Axis 2 in the positive direction.
- H: W+- Detects mechanical origin for Axis 1 in the positive direction, and Axis 2 in the negative direction.
- H: W-+ Detects mechanical origin for Axis 1 in the negative direction, and Axis 2 in the positive direction.
- H: W-- Detects mechanical origin for Axis 1 in the negative direction, and Axis 2 in the negative direction.

(2) M command: Set number of pulses for relative travel

Features: This command is to specify the axis of travel, direction, and the travel (number of pulses). This command must always be followed by a drive (G) command. Travel is by means of acceleration/deceleration driving.

Format:

M: nmPx

Parameter:

- n: 1 or 2 or W Axis number 1 or 2: Moves only one axis, W: Moves both axes.
- m: + or - Direction of move +: + direction move, -: - direction move
- x: moving pulse count 0 - 16777214.
- Example: M: W+P500-P200 Travel 500 pulses in the + direction on the first axis and 200 pulses in the - direction on the second axis
- G

(3) J command: JOG

Features: This command drives stages continuously (at a constant speed) at the starting speed (S). This command must always be followed by a drive (G) command. The stage will stop by an L command.

Format:

J: nm

Parameter:

n : 1 or 2 or W Axis number 1 or 2: Moves only one axis, W: Moves both axes.
 m : + or - Direction of move +: + direction move, -: - direction move

Example:

J : W-+ Move in the - direction on the first axis and in the + direction on the second
 G axis

(4) G command: Drive

Features: When a drive command is issued, the stage starts moving, moves the specified number of pulses, and then stops. The G command is used after M and J commands.

Format:

G Drive

(5) L command: Decelerate and stop

Features: When this command is executed, the stage decelerates and stops.

Format:

L: 1 First axis decelerates and stops
 L: 2 Second axis decelerates and stops
 L: W First- and second-axis decelerate and stop

Note) Stage does not stop even if "L:1", "L:2" at the time "H".
 Stop in "L:W" or "L:E".

(6) L: E command: Emergency stop

Features: This command stops all stages immediately, whatever the conditions.

Format:

L: E Stop first and second axes immediately

(7) R command: Set electronic (logical) origin

Features: This command is used to set electronic (logical) origin to the current position of each axis.

Format:

- R: 1 Set the electronic (logical) origin for the first axis
- R: 2 Set the electronic (logical) origin for the second axis
- R: W Set the electronic (logical) origins for the first- and second-axis

(8) D command: Speed settings

Features: The minimum speed (S), maximum speed (F), and acceleration/deceleration time (R) are set according to the initialize settings when the power is turned on. This command allows you to change these initial settings. The initialize setting is (S): 500PPS, (F): 5000PPS, (R): 200mS.

Format:

D: rSspd11Fspd21Rspd31Sspd12Fspd22Rspd32

Parameter:

- r: 1 or 2 Speed range 1: Low speed range, 2: High speed range
- spd1 Minimum speed(S) 1 - 200PPS (Low range), 50 - 20000PPS (High range)
- spd2 Maximum speed(F) 1 - 200PPS (Low range), 50 - 20000PPS (High range)
- spd3 Acceleration/ Deceleration time (R) 0 - 1000mS (for both High/Low range)

Note) The maximum speed(F) setting should be equal or greater than the minimum speed. If the minimum speed is set to equals to the maximum or the acceleration/ deceleration time is set to zero, stages will move at a constant speed without performing acceleration/ deceleration logically.

Example:

D: 2S100F1000R200S100F1000R200

Sets speeds for Axes1 and 2: Axis1: S = 100PPS, F = 1000PPS, R = 200mS, Axis2: S = 100PPS, F = 1000PPS, R = 200mS.

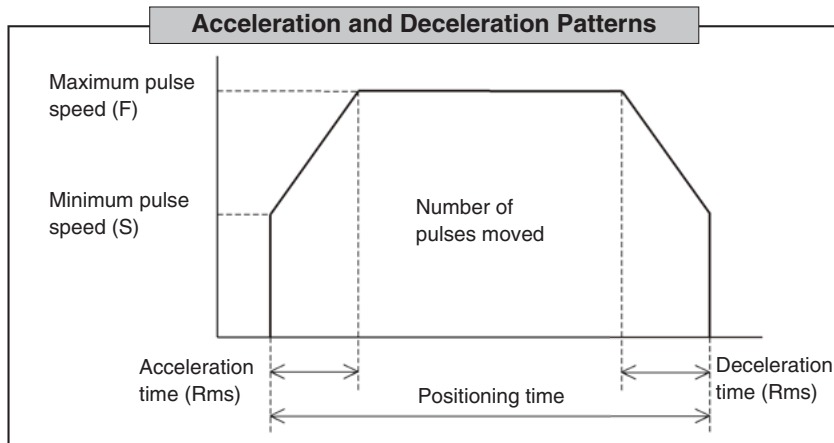

Chapter 4 : Specification

8. Specification

(1) General specifications

Power source	DC+24V
Rating current	2A
Operating temperature	5 to 40°C
Storage temperature	-20 to 60°C
Altitude	up to 2000m
Indoor use only	
Installation category	II
Pollution degree	2
Ambient humidity	20 to 80%RH (no condensation)
External dimensions	180W x125D x40H (excluding projections)
Weight	0.7kg

(2) Performance

Controlling axis	2 axis
Maximum driving speed (F)	1 to 20kPPS
Minimum driving speed (S)	1 to 20kPPS
Acceleration/deceleration time (R)	0 to 1000ms
Sensor input	Origin sensor/proximity sensor/CW (-) limit/CCW (+) limit (Limit sensor logic can be changed with the settings of switch 4 on the DIP Switch.)
Method of return to origin	MINI method/MARK method (Set with switch 3 on the DIP Switch.)
Axes to Home	Axis1/ both axis (1axis and 2axis) (Set with switch 5 on the DIP Switch.)
Interface	RS232C interface Communication Parameters - Baud rate 2400/4800/9600/19200 (Set with switches 1/2 on the DIP Switch.) - Data bits 8 bits - Parity None - Stop bit 1bit - Flow control Hardware (RTS/CTS) - Delimiters CR+LF

(3) Driver Specifications

Driver Mode	Half step driving
Driving (RUN) current	0.3A/phase to 0.8A/phase
Current down function	Automatic current down

(4) Electrical fast transmit/burst immunity EN61000-4-4 (2012) Level2

(5) Electrostatic discharge EN61000-4-2 (2009) Level2.

9. Connector Pin Numbers and Signals

9-1. STAGE1, 2 Connector

No.	Name	No.	Name
1	Blue: motor wiring	9	GND: for Brake
2	Red: motor wiring	10	+24V: for Brake
3	Orange: motor wiring	11	LS (+): limit detection on +
4	Green: motor wiring	12	LS (-): limit detection on-
5	Black: motor wiring	13	GND: common sensor
6	GND: common sensor	14	NEAR: proximity detection
7	ORG: mechanical origin detection	15	+24V: sensor power supply
8	+24V: sensor power supply		

Connector Type D-sub 15pin female connector (mm screw threads)

9-2. RS232C Connector

No.	Name	No.	Name
1	—	6	DTR
2	TxD	7	CTS
3	RxD	8	RTS
4	DSR	9	—
5	SG		

Connector Type D-sub 9pin female connector (inch screw threads)

9-3. SCT602 Connector

No.	Name	No.	Name
1	+24V	6	DTR
2	TxD	7	CTS
3	RxD	8	RTS
4	DSR	9	Reserved
5	SG		

Connector Type D-sub 9pin male connector (mm screw threads)



Do not connect any other devices to the SCT602 connector to avoid possible damage.
You cannot connect to the SCT602 connector and RS232C connector at the same time.

10. Exterior Dimensions

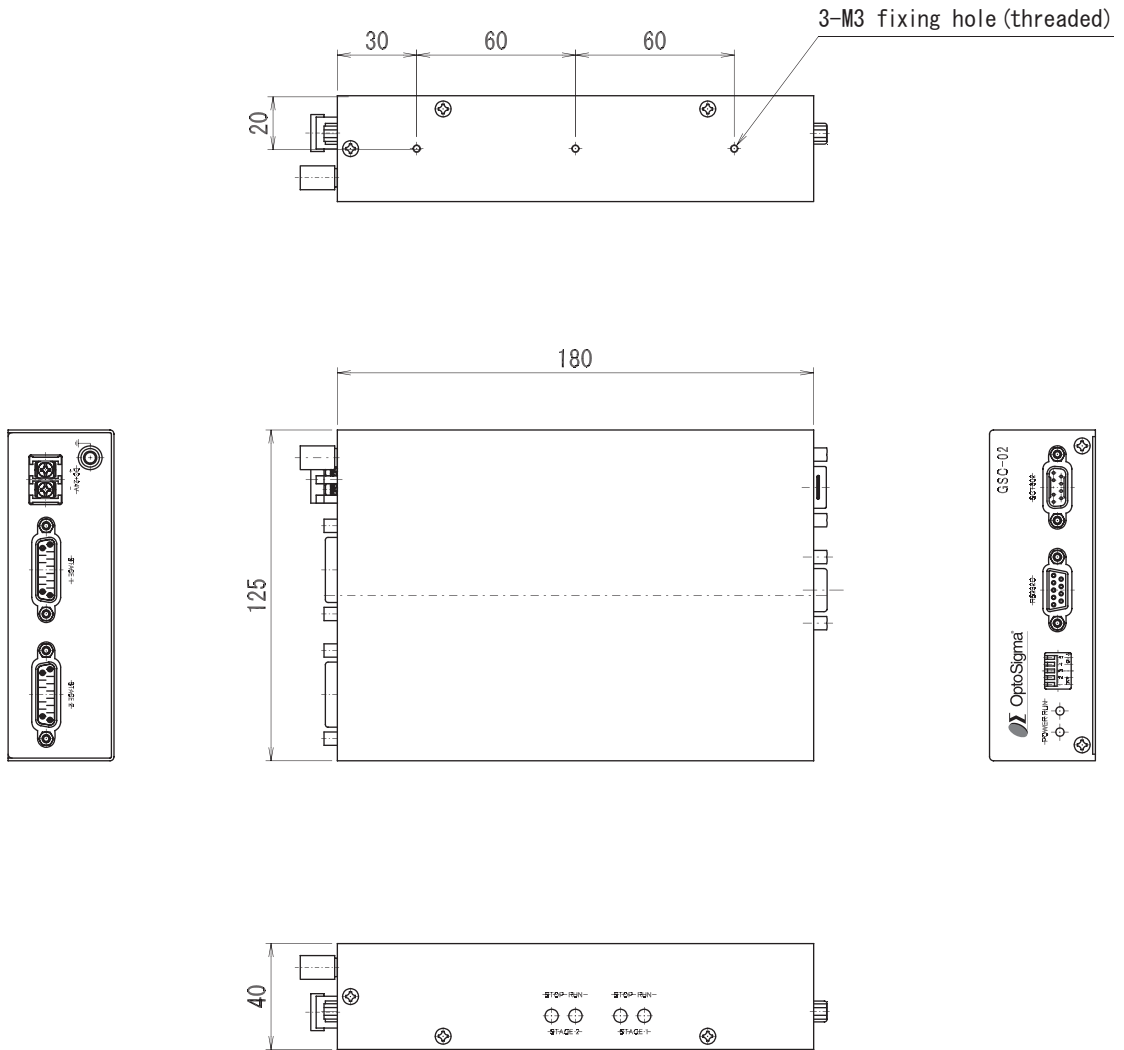

SIGMAKOKI CO., LTD.

<http://www.global-optosigma.com>

Tokyo Head office 1-19-9, Midori, SIGMA KOKI Tokyo Head office, Sumida-ku, Tokyo 130-0021, JAPAN
Tel: +81-3-5638-8228 Fax: +81-3-5638-6550 E-mail: international@sigma-koki.com

Osaka Branch 4-9-28, Nishi-Nakajima, Yodogawa-ku, Osaka 532-0011, JAPAN
Tel: +81-6-6307-4835 Fax: +81-6-6307-4834 E-mail: sales.osaka@sigma-koki.com

Kyushu Sales office 3-17, Hie-machi, Hakata-ku, Fukuoka-shi, Fukuoka 812-0014, JAPAN
Tel: +81-92-481-4300 Fax: +81-92-481-4310 E-mail: sales.kyushu@sigma-koki.com

Technology center 1-1 Yatsukahō, Hakusan-shi, Ishikawa 924-0838, JAPAN